

Functional Range

PLA2 - Generator Power Factor Regulator

CSPC

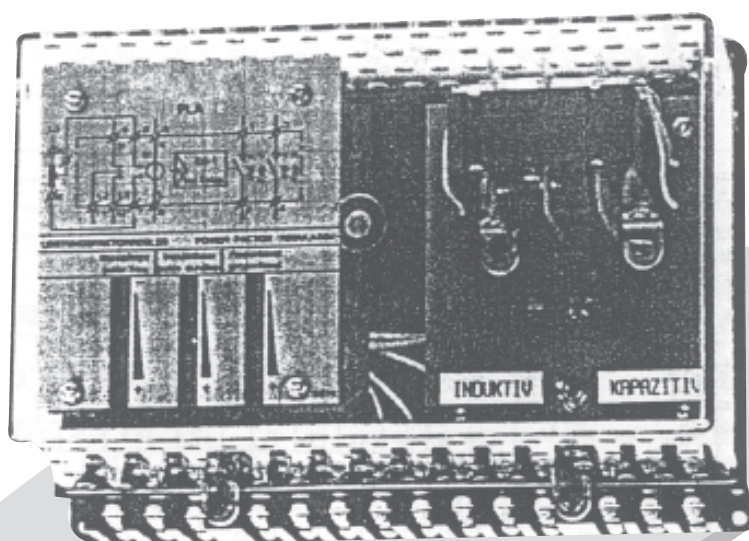

Contents

	Page No.
1. Application	3
2. Mode of operation	3
3. Connection Diagram	3
4. Adjustment of the Regulation Sensitivity	3-4
5. Commissioning	4
6. Technical Data	5
7. Dimensions	6
8. Order Sheet	7

1. Application

The reactive power of a mains parallel operating generator can reach undesirable values by variations of the mains voltage. At reduced mains voltage the reactive power output rises and can lead to overloading of the machine, mains voltage increase leads to absorption of reactive power and with that undesirable mains load (and reactive power costs might possibly be incurred).

2. Mode of Function

Regulator : "PLA2" compares the power factor of the generator with a pre-adjusted nominal value and gives regulating pulses to the adjusting motor of a generator voltage setting potentiometer.

The regulating pulses are adjustable (pulse sequence / intermission time). With that an optimal regulating speed is assured. The supplied adjusting transformer for switchboard front mounting allows as adjuster the setting of a power factor 0.6 to 1, depending on position of the change-over switch in capacitive or inductive direction.

3. Connection Diagram

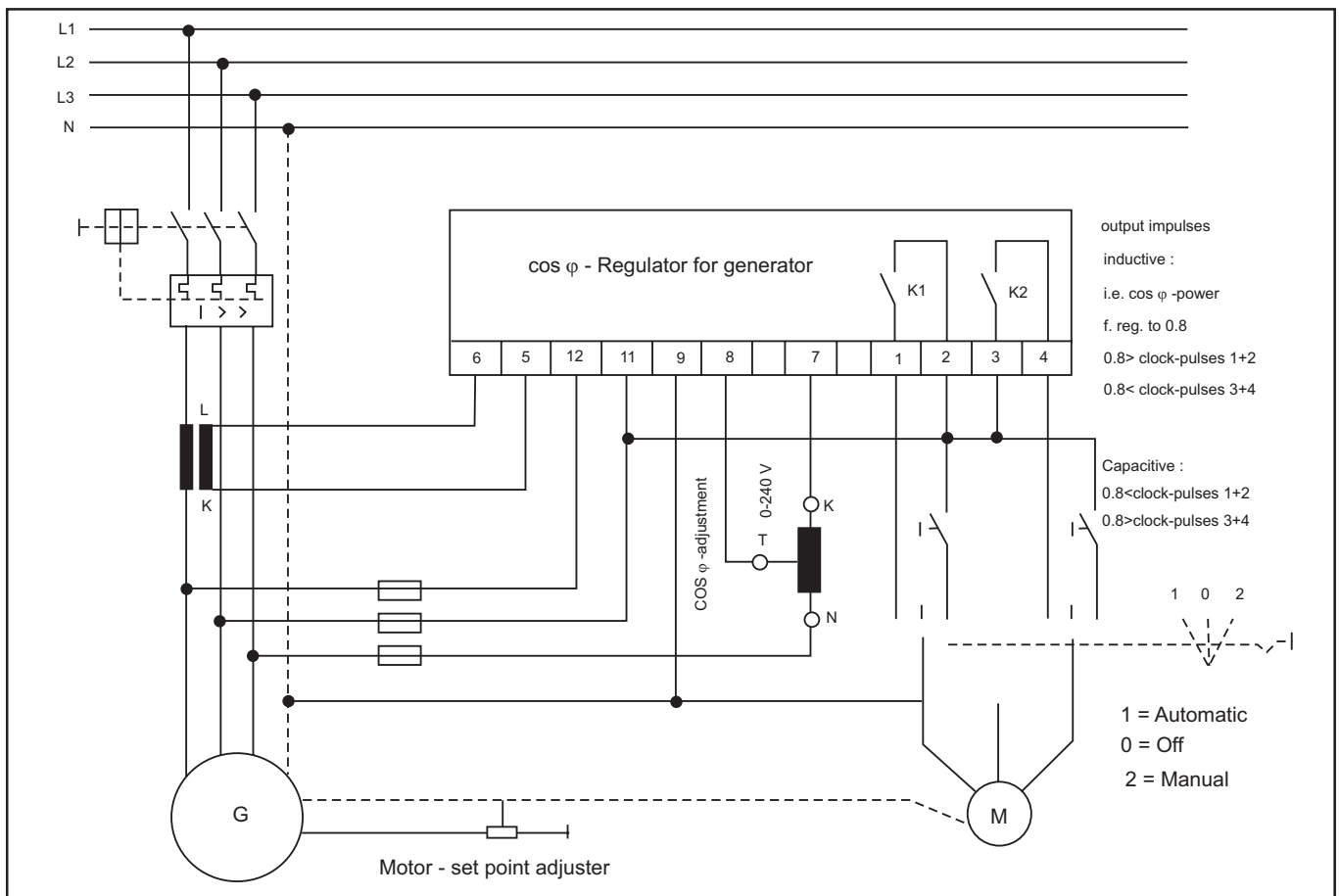

4. Regulation of the Sensitivity

The PLA2 is equipped with 3 spindle potentiometers by means of which the sensitivity can be adjusted.

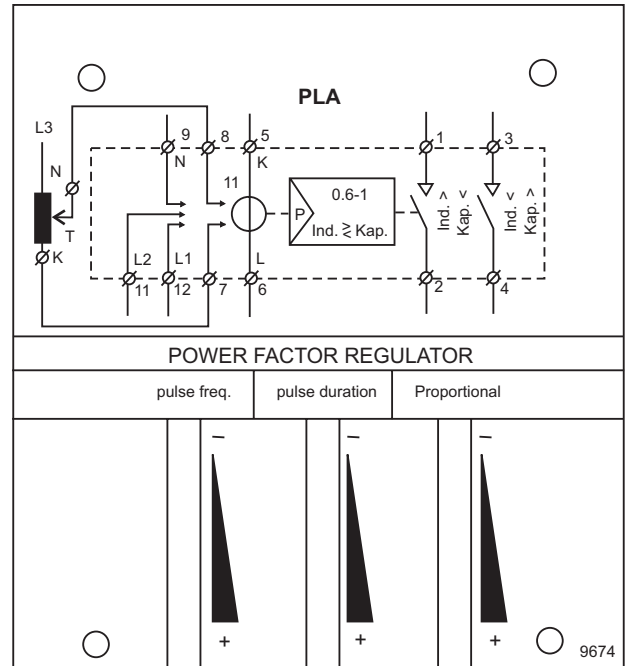

Adjustment of the pulse sequence (tp) at constant pulse duration

A permanent impulse is given. The regulation reacts very sensitive on differing ratings. At existing current differences only few impulses are given e.g. the regulation is insensitive.

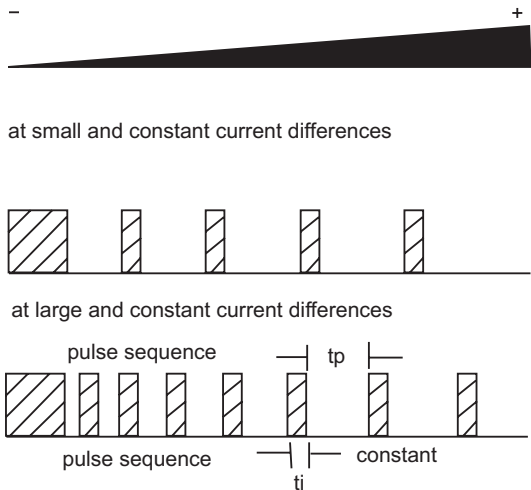

Adjustment of the pulse duration (ti) at constant pulse sequence (tp)

The pulses are completely suppressed. The pulse duration is long

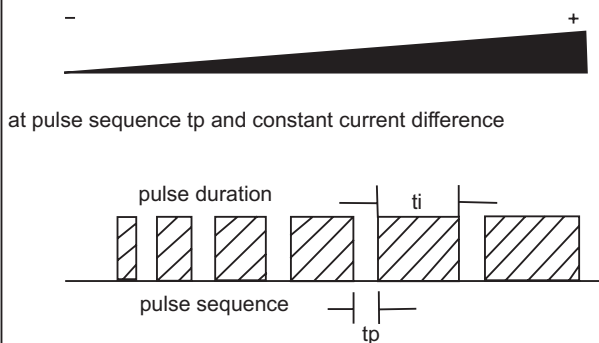

Adjustment of the Regulation Sensitivity (Potentiometer "proportional")

This potentiometer adjustment pre-determines the regulation sensitivity in case of differing current rates is pre-determines, e.g. at small difference there will be slow, at large difference there will be quick re-adjustment.



- If the potentiometer is set to Plus+, there will be re-adjustment, even at a small current difference.



- If the potentiometer is set to Minus- e.g. at a small current difference, no follow-up impulses will be given.



5. Commissioning

The wiring diagram (see page 3) is a suggestion for wiring. The measuring circuit and the set point adjuster have to be connected accordingly. When connecting the regulation impulses, the circuit diagram of the respective motor potentiometers is to be taken into account.

The power factor regulator is only suitable for the mains parallel operation of one generator, in single operation (prime power operation) the regulation impulses have to be interrupted (otherwise, there will be an unintentional adjustment of the generator voltage).

Voltage-regulating Transformer

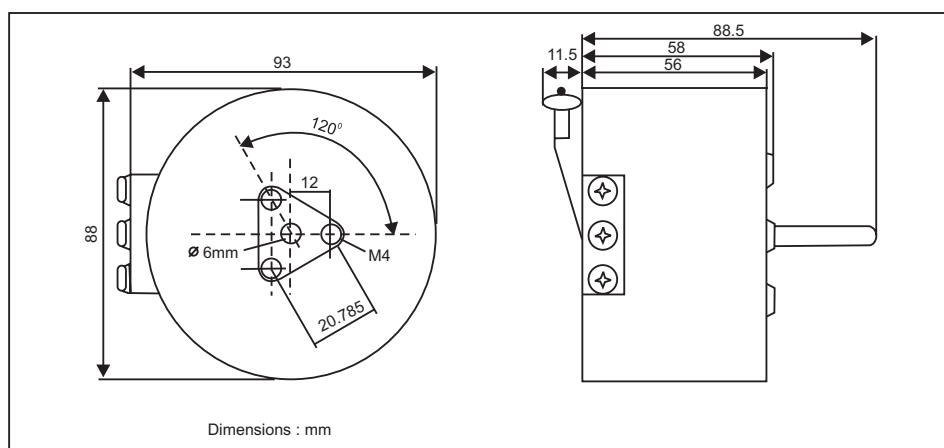

6. Technical Data

PLA2- Generator Power Factor Regulator

General Data

Maintenance	:	maintenance-free
Duty	:	100%
Mounting position	:	optional
Nominal voltage	:	400/230 V, +/- 15%
Nominal current	:	1 or 5 A
Nominal frequency	:	50-60 Hz

Adjustment

Pulse sequence	:	See Para 4. Regulation of the sensitivity
Pulse duration	:	See Para 4. Regulation of the sensitivity
Proportional	:	See Para 4. Regulation of the sensitivity

Output circuits

Potential-free contacts	:	2 N.O. contacts
Contact capacity	:	1000 VA at 250 V/AC or 2 A at 24 V/DC
Contact material	:	silver plated
Contact life	:	10 ⁶ operations
Connection terminals	:	M4, wire termination max. 2.5 mm ²

Ambient conditions

Limits of the ambient temperature

- storage : -40°C to + 70°C
- operation : -20°C to +70°C

7. Dimensions and drill-holes

(Dimension in mm)

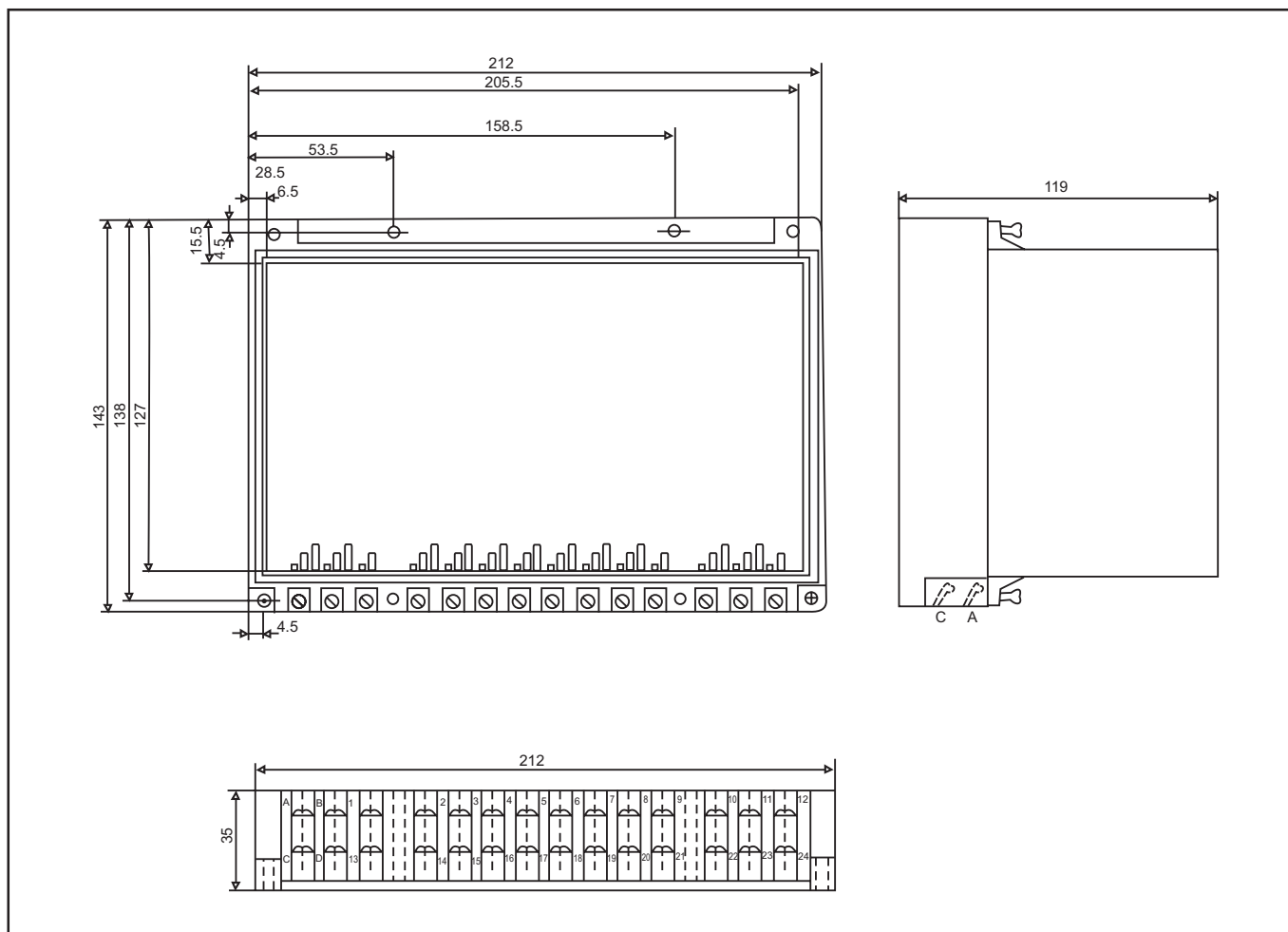

8. Order from

When placing an order, please fill in the adjacent form.

Generator Power Factor Regulator		PLA2	
Number	Measuring voltage	Nominal frequency	Nominal current
<input type="text"/>	PLA2 - <input type="text"/>	- <input type="text"/>	- <input type="text"/>
	110 = 110V AC 230 = 230V AC	50 = 50/60 Hz	1 = 1 A 5 = 5 A



BASIC RANGE

- Micro-controller based compact economical design
- DIN rail mounted
- Status indication via LED
- Step-less settings through front potentiometer



HIGHTECH RANGE

- Microprocessor based numerical protection
- Event & fault recording
- RS 485 communication
- Bright alpha-numeric display



INTEGRATED RANGE

- Complete numeric protection, solution for sub-station in association with TEAM-ARTECHE, Spain
- Distance protection
- Comprehensive transformer protection –
 - a. Three winding transformer
 - b. Two winding transformer
- Multi-functional relay: variety of protection combination

For further information, please contact :



C&S Protection & Control Ltd.

44, Okhla Indl. Estate, New Delhi-110020, Ph.: 011-55602414, 26319465-66 Fax: 011-55602413 email: cspc@controlsindia.com

Marketing Office : DELHI : Ph.: 55602414, 26319465-66 Fax: 55602413 CHANDIGARH : Ph. 2776154, 2776151, 2726153 Fax: 2726154
KOLKATA : Ph. 24549607-08 Fax: 24549371 MUMBAI : Ph.: 24114727-28 Fax : 24126631 PUNE : Ph.: 5444822-824, Fax: 5410820,
AHMEDABAD : Ph.: 65841425, 6589132 Fax : 6589132 BANGALORE : Ph.: 5586147, 5323582, 5594939 Fax: 5582796,
CHENNAI : Ph.: 26426475, 26426572 Fax: 26411972 HYDERABAD : Ph.: 27813003, 55332304 Fax: 27812987