

JetCard 1204 4-port RS-232 Universal PCI Card

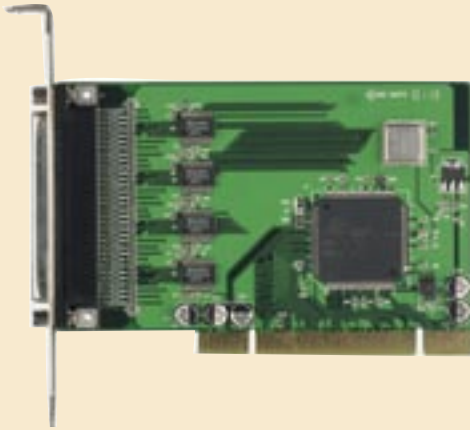

- Supports 32-bit Universal PCI bus
- Easy-to-install driver and self-diagnostic utility
- High speed up to 921.6 Kbps
- Built-in 15KV ESD protection
- Supports 128-byte FIFO
- Supports on-board automatic hardware/software flow control



Overview

JetCard 1204 is Korenix's 4-port RS-232 Universal PCI Multiport Serial Card. The self-diagnostic utility and the easy-to-install driver that come with JetCard make it easier for you to set up your complex system. JetCard built-in 15KV ESD surge protection protects your system from power surges

and voltage spikes. With its powerful features and functions, JetCard 1204 is your perfect choice for applications in building automation, security, retail and POS systems, billboard broadcasting, and telecom management.

High Performance

JetCard Series uses Oxford OXmPCI954 chip, a 4-port Universal Asynchronous Receiver Transmitter, which is well-known for its high performance. Each UART channel in the JetCard offers data transmission speed up to 921.6 Kbps, and bi-directional 128-byte FIFO for each port. Deep FIFO can reduce the CPU's loading, saving CPU's resources for other important tasks. This chip also allows JetCard to be compatible with the widely-used industry-standard 16C550 devices and PCI bus.

In addition to high speed of 921.6 Kbps and 128-byte FIFO, Oxford chip also equips JetCard with on-board flow control function. Instead of using a driver on the PC to control the traffic flow, JetCard uses the on-board flow control function to

reacts directly without waiting for the PC to respond. In this way, the respond time and CPU's loading can be largely reduced, greatly enhancing your system's performance. You can either choose software flow control, which uses Tx and Rx to send/ receive XON/XOFF signals, or select hardware flow control, which uses CTS#/RTS# to send/ receive the signals. The flow control function is to prevent FIFO from overflow. JetCard is ideally suitable for PC applications, enabling PC users to take advantage of the maximum performance of analog modem or ISDN terminal adapters. JetCard is also suitable for any communications that require high speed RS-232/RS-422/RS-485 interfaces.

Multiport Serial Card

Specifications

Interface

Bus Interface : 32-bit Universal PCI

Number of Ports: 4

Max. Number of Boards: 4

IRQ: Assigned by PCI plug and play

Data Bits : 5, 6, 7, 8

Stop Bits: 1, 1.5, 2

Parity Bits: None, Even, Odd, Space, Mark

Data Signals: TxD, RxD, RTS, CTS, DTR, DSR, DCD, GND

Hardware

Communication Controller: 16C950 compatible (OXFORD)

Board Connector: DB37 Female

Cable Connection:

DB9 Male or DB25 Male, 100 cm cable length

Cable Model:

CM37M9x4-100 or CM37M25x4-100 (optional)

Performance

FIFO Size: 128 Bytes

Speed: 50 bps to 921.6 Kbps

Surge Protection : Embedded 15KV ESD Surge Protection

Power Requirements

Power Consumption: 120 mA (+5 V)

Mechanical

Dimensions: 120 x 80 mm

Environmental

Operating Temperature: -10°C to 70°C (14°F to 158°F)

Operating Humidity: 5% to 95 % (Non-condensing)

Storage Temperature: -20°C to 85°C (-4°F to 185°F)

OS Supported:

Windows 98/Me/NT/2000/XP/2003,

Linux RedHat Enterprise 4.0 (2.6.9)/RedHat Enterprise 3.0 (2.4.21)/

RedHat 9.0 (2.4.20)/RedHat 8.0 (2.4.18)/RedHat 7.3 (2.4.18)/

RedHat 7.2 (2.4.7)/FC3(2.6.9)/FC2(2.6.5)/FC1(2.4.22)/

Mandrake 10.1(2.6.8)/Mandrake 9.2 (2.4.22)

Regulatory Approvals

EMI : FCC, CE

Warranty : 5 years

Pin Assignments

RS-232 DB9 Male

Pin No.	Signal
1	DCD
2	RxD
3	TxD
4	DTR
5	GND
6	DSR
7	RTS
8	CTS

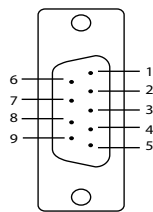

RS-232 DB25 Male

Pin No.	Signal
2	TxD
3	RxD
4	RTS
5	CTS
6	DSR
7	GND
8	DCD
20	DTR

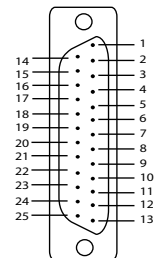

Ordering Information

JetCard 1204 4-port RS-232 Universal PCI Card

Includes:

- 4-port RS-232 Card
- Quick Installation Guide
- Documentation and Software CD-ROM

Optional Accessories

CM37M9x4-100 4-port male DB37 to male DB9 connection cable, 100cm

CM37M25x4-100 4-port male DB37 to male DB25 connection cable, 100cm